

# ION9000 Series Technical Data Sheet

The PowerLogic™ ION9000 is your 24/7 power quality expert, providing information, not just data.

This meter offers a comprehensive and industry leading Power Quality Instrument (PQI) performance designation according to IEC 62586-1/-2. It provides the highest accuracy in industry according to ANSI C12.20 Class 0.1 and IEC 62053-22 Class 0.1S. Third-party, lab-verified power quality, accuracy and safety ensure reliable performance and demonstrates the meter's suitability for both supply and demand side applications.

Identify the source of power quality issues faster with our patented Disturbance Direction Detection. Protect your future through highly customizable modularity and field programmability to satisfy any solution. All backed by Schneider Electric's global services and support.

## Applications

Ideal for low to high voltage applications in industrial facilities, data centers, infrastructure and other critical power environments.

FB115917



METSEION92040

### The market solution for

Markets that benefit from a solution that includes PowerLogic ION9000 series meters:

- Data centers
- Healthcare facilities
- Semiconductor
- Pharmaceutical & chemical
- Energy industries
- Mining, Minerals, & Metals
- Renewable energy interconnects
- Medium voltage distribution & energy automation

### Benefits

- Makes understanding power quality simple which helps operations personnel avoid downtime and increase productivity and equipment life
- Makes energy and power quality data immediately actionable and relevant to operational and sustainability goals

### Competitive advantages

- Modular, flexible, patented ION™ programmable technology
- Utility grade energy accuracy
- Patented Disturbance Direction Detection
- Third-party, lab-verified compliance with latest PQ standards
- Onboard pass/fail PQ characterization and assessment according to EN50160 and IEEE519
- Cybersecurity event logging, Syslog protocol, HTTPS, and full control of each communication port

### Power management solutions

Schneider Electric provides innovative power management solutions to increase your energy efficiency and cost savings. Maximize electrical network reliability and availability, and optimize electrical asset performance.

### Conformity of standards

- ANSI C12.20
- ANSI C37.90.1
- IEC 61000-4-15
- IEC 61000-4-30
- IEC 61010-1
- IEC 61326-1
- IEC 61557-12
- IEC 61850
- IEC 62052-11
- IEC 62052-31
- IEC 62053-22
- IEC 62053-23
- IEC 62053-24
- IEC 62586
- UL 61010-1

### Main characteristics



PowerLogic™ ION9000 series meter with RD192 display



PowerLogic™ ION9000 RD192 remote display



PowerLogic™ ION9000 front view

- PQ compliance reporting and basic PQ analysis:
  - Monitors and logs parameters in support of international PQ standards:
    - IEC 61000-4-30 Class A (test methods as per IEC 62586-2).
  - High resolution waveform capture: triggered manually or by alarm. Captured waveforms available directly from the meter via FTP in a COMTRADE format, and viewable in the meter's web interface.
  - Generates onboard PQ compliance reports accessible via onboard web pages:
    - Pass/fail report for IEEE 519 for voltage and current harmonic limits.
    - ITIC (CBEMA) and SEMI curves, with alarm categorization to support further analyses.
    - NEMA Motor Derating curve.
  - Harmonic analysis:
    - THD and TDD per phase, min/max, custom alarming.
    - Individual harmonic magnitudes and angles on voltage and current, up to the 63rd harmonic.
  - Disturbance detection and capture: sag/swell on any current and voltage channel, alarm on disturbance event, waveform capture with per-event information.
  - Patented Disturbance Direction Detection: provides indication of the captured disturbance occurring upstream or downstream of the meter; timestamped results provided in the event log, with degree of certainty of disturbance direction.
- Transient capture of events 20 microseconds or longer in duration on any voltage channel with waveform capture and per-event information.
- Metering precision:
  - IEC 61557-12 PMD/SD/K70/0.2 and PMD/SS/K70/0.2 3000m (Performance Measuring and Monitoring devices (PMD)).
  - Class 0.1S accuracy IEC 62053-22, ANSI C12.20 Class 0.1 (active energy).
  - Industry leading Class 0.5S accuracy for reactive energy (IEC 62053-24).
  - Cycle-by-cycle RMS measurements updated every ½ cycle.
  - Full 'multi-utility' WAGES metering support.
  - Net metering.
  - Anti-tamper protection seals and hardware metrology lock.
- Cybersecurity:
  - Security events logging with Syslog protocol support.
  - HTTPS secure protocol.
  - Ability to enable or disable any communication port and any protocol per port.
  - Anti-tamper protection seals and hardware metrology lock.
  - User accounts with strong passwords.

PB115916



PowerLogic ION9000 with panel mounting adapter

PB115919



PowerLogic ION9000 front with two option modules

PB115920



PowerLogic ION9000 bottom with two option modules

- Used with Schneider Electric’s advanced software tools, provides detailed PQ reporting across entire network:
  - EN 50160 compliance report.
  - IEEE 519 harmonic compliance report.
  - IEC 61000-4-30 report.
  - Power quality compliance summary.
  - Energy reports for consumption analysis and cost management.
  - WAGES dashboards and reports.
  - Display of waveforms and PQ data from all connected meters.
  - Onboard web-based waveform viewer.
  - EcoStruxure Power Events Analysis, including alarm management, sequence of events, and root cause analysis.
  
- Data and event logging:
  - Onboard data and event logging.
  - 2 GB of standard non-volatile memory.
  - No data gaps due to network outages or server downtime.
  - Min/max log for standard values.
  - 100 user-definable data logs, recording up to 16 parameters at a 1/2 cycle or other user definable interval.
  - Continuous logging or snapshot, triggered by setpoint and stopped after defined duration.
  - Trend energy, demand and other measured parameters.
  - Forecasting via web pages: average, minimum and maximum for the next four hours and next four days.
  - Advanced time-of-use capability.
  - Security/event log: alarm conditions, metering configuration changes, power outages, firmware download, and user login/logout with timestamp.
  
- Alarming and control:
  - 50+ definable alarms to log critical event data, trigger waveform recording, or perform control function.
  - Trigger on any condition, with 1/2-cycle and 1-second response time.
  - Combine alarms using Boolean logic enabling customization of alarms.
  - Alarm notification via email.
  - In conjunction with Schneider Electric’s EcoStruxure software, alarms, software alarms, and alarm frequency are categorized and trended enabling sequence of events and root cause analyses.

**Usability**

- On-board, full function web server enables simple web commissioning:
  - Panel and DIN rail mounting options, remote display option.
  - Pluggable connectors.
  - Free setup wizard simplifies meter configuration.
  - Auto-discovery using DPWS (Device Profile Web Services).
  - DHCP for automatic IP address configuration.
  
- Front panel:
  - Easy to read color graphic display.
  - Simple and intuitive menu navigation with multiple language interface and support.



PowerLogic ION9000 Harmonics display

- Flexible remote communications:
  - Multiple simultaneously operating communication ports and protocols allow interfacing with other automation systems, e.g. waveforms, alarms, billing data, etc. Data can be uploaded for viewing/analysis while other systems access real-time information.
  - Supports: Modbus, ION, DNP3, DLMS, SNMP, and IEC 61850.
  - Dual port Ethernet: 2x 10/100BASE-TX; supports IPV4 and IPV6; daisy-chaining capability removes need for additional switches.
  - Create redundant network loop using Rapid Spanning Tree Protocol (RSTP) and managed Ethernet switches.
  - Secure web interface with HTTPS and TLS 1.2 with support for user-provided certificates.
  - Customize TCP/IP port numbers and enable/disable individual ports.
  - RS-485 2-wire connection, up to 115,200 baud.
  - Ethernet to serial gateway with Modbus Master functionality, connecting to 31 unit loads of downstream serial Modbus devices. Also supports Modbus Mastering over TCP/IP (Ethernet) network.
  - Full function web server with factory and customizable pages to access real-time and PQ compliance data.
  - Push historical data via email.
  - Advanced network security: Up to 50 configurable user accounts.
  
- Time synchronization via:
  - Precision network time protocol (PTP) based on IEEE 1588 / IEC 61588.
  - GPS clock (RS-485) or IRIG-B (digital input) to ±1 millisecond.
  - Network Time Protocol (NTP/SNTP).
  - Automatic time synchronization available through Schneider Electric software server.

### Adaptability

- ION™ frameworks are customizable, scalable applications with object-oriented programming that compartmentalizes functions, and increases flexibility and adaptability.
- Applications include: access and aggregate data from Modbus devices on serial port or across the network (Modbus TCP/IP), logging and/or processing data by totaling, unit conversion or other calculations, applying complex logic for alarming or control operations, data visualization via web pages.

### Standard meter I/O

- 8 digital status/counter inputs with ±1 millisecond timestamp.
- 4 solid state digital outputs (Form A) for energy pulsing, interfacing with other systems or control.
- 2 Form C relay outputs for control applications.

### Modular I/O options

- Optional expansion modules.
- Up to 4 modules per meter.

Option modules include:

- Digital module:
  - 6 digital status/counter inputs.
  - 2 Form C relay outputs, 250 V AC, 8 A.
- Analog module:
  - 4 analog inputs (4-20 mA; 0-30 V).
  - 2 analog outputs (4-20 mA; 0-10 V) for interfacing with building management sensors and systems.

# ION9000 series

## Feature guide

<b>General</b>
Use on LV, MV, and HV systems
Current accuracy: 0.1 % reading
Voltage accuracy: 0.1 % reading
Active energy accuracy: 0.1 Class
Number of samples/cycle or sample frequency: 1024
<b>Instantaneous rms values</b>
Current, voltage, frequency
Active, reactive, apparent power: Total and per phase
Power factor: Total and per phase
<b>Energy values</b>
Active, reactive, apparent energy
Settable accumulation modes
<b>Demand values</b>
Current: Present and max. values
Active, reactive, apparent power: Present and max. values
Predicted active, reactive, apparent power
Synchronization of the measurement window
Setting of calculation mode: Block, sliding
<b>Power Quality measurements</b>
Harmonic distortion: Current and voltage
Individual harmonics: via front panel and web page: 63 via EcoStruxure™ software: 511
Waveform capture
Detection of voltage swells and sags
Fast acquisition: 1/2 cycle data
EN 50160 compliance checking
Customizable data outputs (using logic and math functions)
IEEE 519 compliance checking
<b>Data recording</b>
Min/max of instantaneous values
Data logs
Event logs
Trending/forecasting
SER (Sequence of event recording)
Time stamping
PTP, IRIG-B, and GPS time synchronization ( $\pm 1$ ms)
Memory: 2000 MB
<b>Display and I/O</b>
Front panel display, 2 options: 96 mm & 192 mm
Pulse output: 2
Digital or analog inputs (max): 32 digital, 16 analog
Digital or analog outputs (max, including pulse output): 4 digital, 10 relay, 8 analog
<b>Communication</b>
RS-485 port(s): 2
Ethernet port(s): 2x 10/100BASE-TX, RJ45 connector, CAT5/5e/6/6a cable
Serial port protocols (Modbus, ION, DNP3, DLMS)
Ethernet port protocols (Modbus, ION, DNP3, DLMS, IEC 61850)
Ethernet gateway
Alarm notification via email
HTTP/HTTPS web server with waveform viewer
SNMP with custom MIB and traps for alarms
SMTP email
PTP and NTP time synchronization
FTP file transfer

# ION9000 series

## Technical specifications

Electrical characteristics		
Type of measurement		True rms to 1,024 samples per cycle
Measurement accuracy	Current & voltage	Class 0.1 as per IEC 61557-12
	Active Power	Class 0.1 as per IEC 61557-12
	Power factor	Class 0.5 as per IEC 61557-12
	Frequency	Class 0.02 as per IEC 61557-12
	Active energy	Class 0.1S IEC 62053-22 Class 0.1 IEC 61557-12 Class 0.1 ANSI C12.20
	Reactive Energy	Class 0.5S IEC 62053-24
Display refresh rate		HMI display updated once per second; data refresh rate 1/2 cycle or 1 second
Input-voltage characteristics	Specified accuracy voltage	57 - 400 V L-N / 100 - 690 V L-L
	Impedance	5 MΩ per phase
	Specified accuracy frequency	42 to 69 Hz (50/60 Hz nominal)
	Limit range of operation - frequency	20 to 450 Hz
Input-current characteristics	Rated nominal current	1 A (0.1S), 5 A (0.1S); current class 2, 10, 20 A (0.1 ANSI)
	Specified accuracy current range	Starting Current: 1 mA (no accuracy) Accurate Range: 10 mA - 20 A
	Permissible overload	500 A rms for 1.0s
	Impedance	0.0003 Ω per phase
	Burden	0.01 VA max at 5 A
Power supply AC/DC	AC	90-480 V AC ±10 % (50/60 Hz ±10 %) 90-120 V AC ±10% (400 Hz)
	DC	110-480 V DC ±15 %
	Ride-through time (Values for meters with no optional accessories)	100 ms (5 cycles at 50/60 Hz) typ., 120 V AC 400 ms (20 cycles at 50/60 Hz) typ., 240 V AC 1,200 ms (60 cycles at 50/60 Hz) typ., 480 V AC
	Burden	Typical: 16.5 W / 38 VA at 480 V (50/60 Hz) Fully optioned: max. 40 W / 80 VA at 480 V (50/60 Hz).
Input/outputs	Meter base Only	8 digital inputs (30 V AC/60 V DC) 4 Form A (KY) solid state digital output (30 V AC/60 V DC, 75 mA) 2 Form C relays (8 A at 250 V AC, 5 A at 24 V DC)
	Optional	Digital - 6 digital inputs (30 V AC / 60 V DC) wetted + 2 Form C relay outputs (250 V AC, 8 A) Analog - 4 analog inputs (4-20 mA, 0-30 V DC) + 2 analog outputs (4-20 mA, 0-10 V DC).
Mechanical characteristics		
Weight		DIN rail mount meter 1.5 kg I/O modules 0.140 kg Touchscreen display 0.300 kg
IP degree of protection		IP 65, UL type 12: Panel mount and touchscreen display, front. IP 30: Panel mount rear, DIN rail mount, I/O modules.
Excellent quality		ISO 9001 and ISO 14000 certified manufacturing.
Dimensions	Panel mount	160 x 160 x 135.3 mm
	DIN rail mount meter	160 x 160 x 135.3 mm
	Color remote display (2 options)	197 x 175 x 27.5 mm touchscreen 96 x 96 x 27 mm pushbutton
	I/O modules	90.5 x 90.5 x 22 mm
	Touchscreen display(s)	192 mm and 96 mm



# ION9000 series

Environmental conditions	
Operating temperature	-25 to 70 °C
Remote Display Unit	-25 to 60 °C
Storage temperature	-40 to 85 °C
Humidity rating	5 to 95 % non-condensing
Installation category	III
Operating altitude (maximum)	3,000 m above sea-level
Electromagnetic compatibility	
EMC standards	IEC 62052-11, IEC 61326-1, IEC 61000-6-5
Immunity to electrostatic discharge	IEC 61000-4-2
Immunity to radiated fields	IEC 61000-4-3
Immunity to fast transients	IEC 61000-4-4
Immunity to surges	IEC 61000-4-5
Immunity to conducted disturbances	IEC 61000-4-6
Immunity to power frequency magnetic fields	IEC 61000-4-8
Immunity to conducted disturbances, 2-150kHz	CLC/TR 50579
Immunity to voltage dips & interruptions	IEC 61000-4-11
Immunity to ring waves	IEC 61000-4-12
Conducted and radiated emissions	EN 55011 and EN 55032 Class B, FCC part 15 Class B, ICES-003 Class B
Surge withstand Capability (SWC)	IEEE/ANSI C37.90.1
Safety	
Safety Construction	IEC/EN 61010-1 ed.3, CAT III, 400 V L-N / 690 V L-L UL 61010-1 ed.3 and CSA-C22.2 No. 61010-1 ed.3, CAT III, 347 V L-N / 600 V L-L IEC/EN 62052-31, protective class II.
Communication	
Ethernet to serial line gateway	Communicates directly with up to 31 serial devices.
Web server	Customizable pages, new page creation capabilities, HTML/XML compatible.
Serial port RS-485	2x, Baud rates of 2,400 to 115,200, pluggable screw terminal connector.
Ethernet port(s)	2x 10/100BASE-TX, RJ45 connector, CAT5/5e/6/6a cable.
Protocol	HTTPS, FTP, SNMP, SMTP, DPWS, RSTP, PTP, NTP/SNTP, GPS, Syslog, DHCP, IPv4, IPv6.
Firmware characteristics	
High-speed data recording	Down to 1/2 cycle interval recording, stores detailed characteristics of disturbances or outages. Trigger recording by a user-defined setpoint, or from external equipment.
Harmonic distortion	Up to 63rd harmonic (511th via Schneider Electric EcoStruxure software) for all voltage and current inputs.
Sag/swell detection	Analyze severity/potential impact of sags and swells: magnitude and duration data suitable for plotting on voltage tolerance curves per phase triggers for waveform recording.
Disturbance direction detection	Determine the location of a disturbance more quickly and accurately by determining the direction of the disturbance relative to the meter. Results are captured in the event log, along with a timestamp and confidence level indicating level of certainty.
Detection and capture of transients	As short as 20 µs at 50 Hz (17 µs at 60 Hz)
Instantaneous	High accuracy of standard speed (1s) and high-speed (1/2 cycle) measurements, including true rms per phase and total for: voltage, current, active power (kW), reactive power (kvar), apparent power (kVA), power factor, frequency, voltage and current unbalance, phase reversal.
Load profiling	Channel assignments (1600 channels via 100 recorders) configurable for any measurable parameter, including historical trend recording of energy, demand, voltage, current, power quality, or any measured parameter. Trigger recorders based on time interval, calendar schedule, alarm/event condition, or manually.
Trend curves	Historical trends and future forecasts to better manage demand, circuit loading, and other parameters. Provides average, min, max, and standard deviation every hour for last 24 hours, every day for last month, every week for last 8 weeks and every month for last 12 months.
Waveform captures	Simultaneous capture of voltage and current channels, sub-cycle disturbance captures of 180-cycles @ 1,024 samples/cycle to 7,200-cycles @ 16 sample/cycle, retriggerable.
Alarms	Threshold alarms: adjustable pickup and dropout setpoints and time delays, numerous activation levels possible for a given type of alarm, user-defined or automatic alarm threshold settings, user-defined priority levels (optional automatic alarm setting).
Advanced Time of Use (TOU)	4 seasons; 5 different day types: weekend, weekday, and holiday; up to 4 tariffs per day type.



# ION9000 series

Firmware characteristics (cont.)	
Advanced network security	Up to 50 users with unique access rights. Perform resets, time sync, or meter configurations based on user privileges.
Memory	2,000 MB.
Firmware update	Update via the communication ports.
Display characteristics	
96 mm pushbutton display	320 x 240 (1/4 VGA) color LCD, configurable screens , 5 buttons and 2 LED indicators (alarm and meter status).
192 mm touchscreen display	800 x 400 pixels, 177.8 mm (7") Color LCD, +/- 85 degree view angle, sunlight readable, dual capacitive touch, usable when wet or through Class 0 lineman gloves, impact resistant to 5 joules, IP65 rating.
Languages	English, French, Spanish, Russian, Portugese, German, Italian, Chinese.
Notations	IEC, IEEE.
The HMI menu includes	
Alarms	Active alarms, historic alarms (50+ alarms).
Basic reading	Voltage, current, frequency, power summary.
Power	Power summary, demand, power factor.
Energy	Energy total, delivered, received.
Events	Timestamped verbose event log.
Power Quality	EN 50160, IEEE 519, harmonics, phasor diagrams.
Inputs/Outputs	Digital inputs, digital outputs, relay outputs, analog inputs, analog outputs.
Nameplate	Model, serial and FW version.
Custom screens	Build your own metrics.
Setup menu	Meter setup, communications setup, display setup, date/time/clock setup, alarm setup, language setup, time of use setup, resets, password setup.

## ION9000 Commercial reference numbers

Commercial reference number	Description
<b>METSEION92030</b>	ION9200 meter, DIN mount, no display, HW kit
<b>METSEION92040</b>	ION9200 meter, DIN mount, 192 mm display, B2B adapter, HW kit
<b>METSEPM89RD96</b>	Remote display, color LCD, 96 x 96 mm
<b>METSERD192</b>	Remote display, color touchscreen, 192 x 192 mm
<b>METSEPM89M2600</b>	I/O module, 2 relay outputs, 6 digital inputs
<b>METSEPM89M0024</b>	I/O module, 2 analog outputs, 4 analog inputs
<b>METSE9HWK</b>	ION9000 meter hardware kit – plugs, terminal guards, spare grounding screw, DIN clips
<b>METSERD192HWK</b>	RD192 remote display hardware kit
<b>METSE9B2BMA</b>	ION9000 B2B adapter
<b>METSE9USBK</b>	ION9000 USB cover hardware kit
<b>METSE9CTHWK</b>	ION9000 Current Input hardware kit – terminal screws, CT covers
<b>METSE7x4MAK</b>	ION7x50 Mounting Adapter Kit

Contact your Schneider Electric representative for complete ordering information.

# ION9000 series

## ION9000 meter dimensions

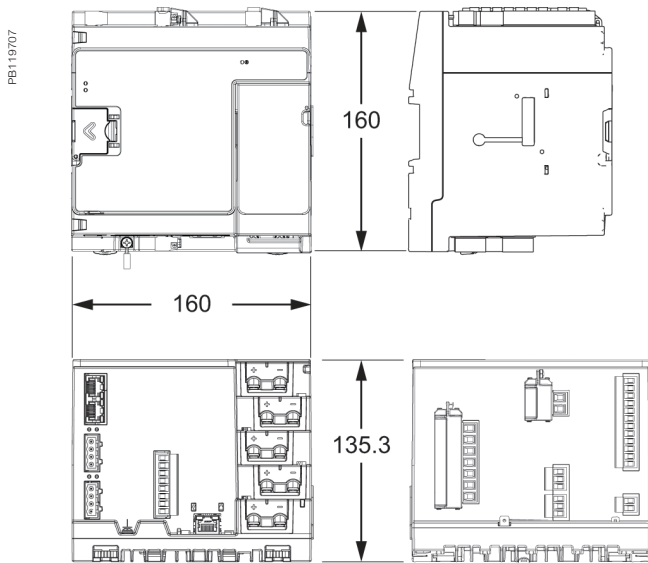

## ION9000 mounting template

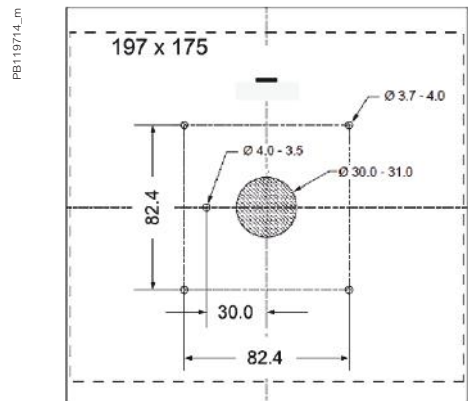

## ION9000 back-to-back (B2B) dimensions

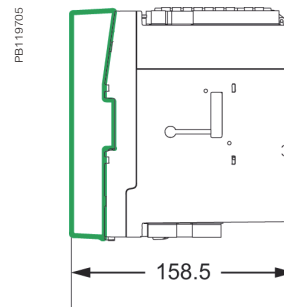

## ION9000 192 mm display dimensions

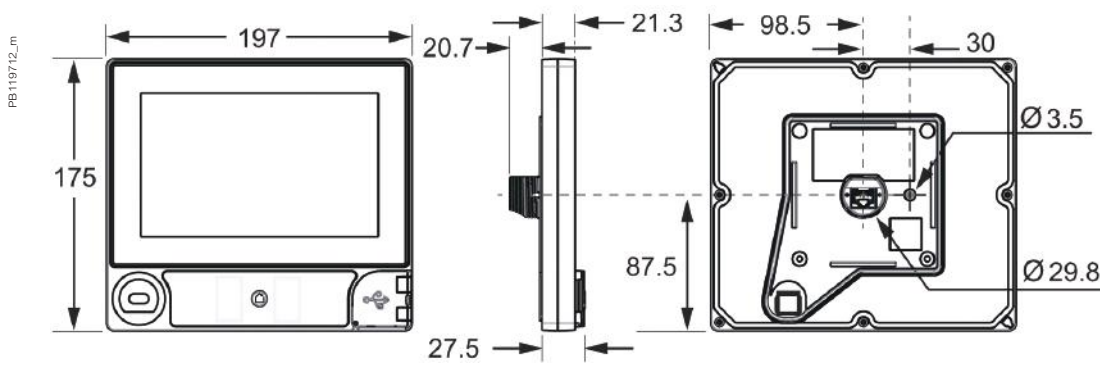

## ION9000 96 mm display dimensions

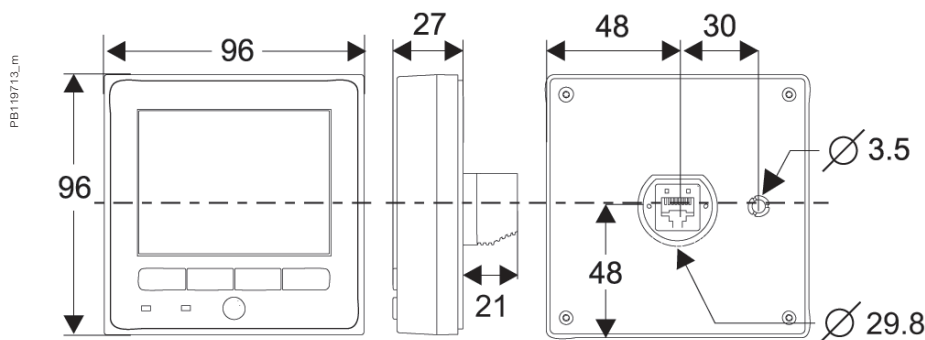

Please refer to ION9000 Series Meter Installation Sheet for accurate and complete information on the installation of this product.

# ION9000 series

## ION9000 meter DIN rail dimensions

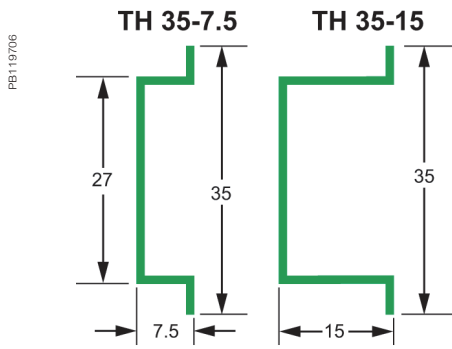

## ION7x50 mounting adapter dimensions

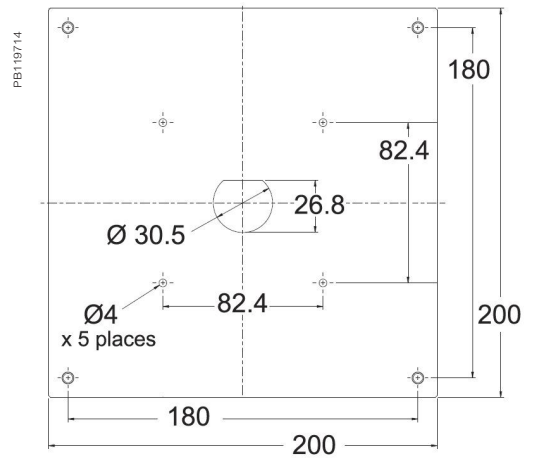

## ION9000 meter click installation

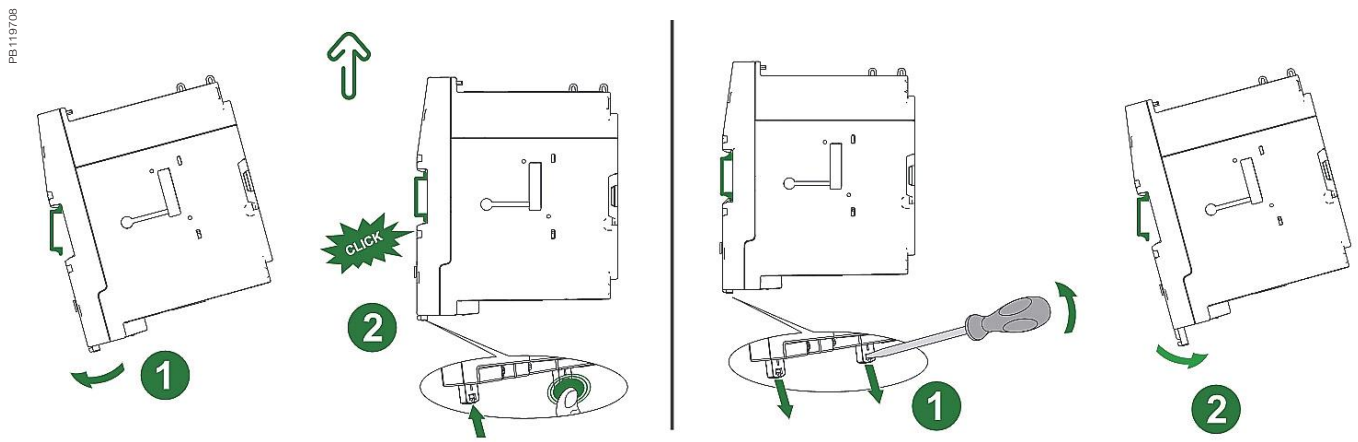

Schneider Electric Industries SAS  
35, Rue Joseph Monier,  
CS 30323  
F - 92506 Rueil Malmaison Cedex

RCS Nanterre 954 503 439  
Capital social 896 313 776  
[www.schneider-electric.com](http://www.schneider-electric.com)

ION9000 Series Meter  
**PLSED310106EN**

As standards, specifications and designs develop from time to time, please contact Schneider Electric for confirmation of the information given in this document.

Design: Schneider Electric  
Photos: Schneider Electric

Over 75 % of Schneider Electric products  
have been awarded the Green Premium ecolabel.



© 2018 - Schneider Electric - All rights reserved.

08-2018

Life Is On

**Schneider**  
Electric